

IMPORTANT INSTRUCTIONS
FOLLOW CAREFULLY OR GUARANTEE MAY BE VOID

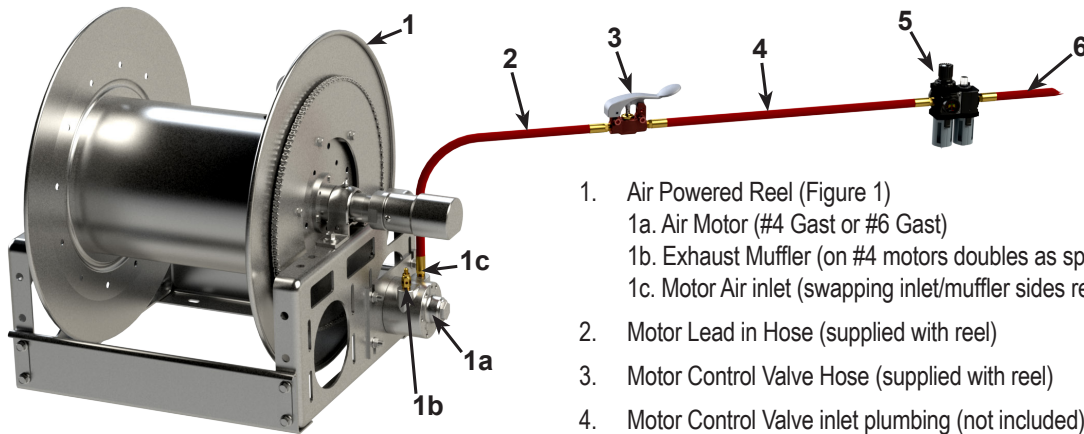

FIGURE 1: Air Powered Reel & Components

1. Air Powered Reel (Figure 1)
 - 1a. Air Motor (#4 Gast or #6 Gast)
 - 1b. Exhaust Muffler (on #4 motors doubles as speed control)
 - 1c. Motor Air inlet (swapping inlet/muffler sides reverses motor)
2. Motor Lead in Hose (supplied with reel)
3. Motor Control Valve Hose (supplied with reel)
4. Motor Control Valve inlet plumbing (not included)
5. FRL (Filter, Regulator, Lubricator Combination - not included) should be mounted close to reel, within 20 feet (Note: separate components may be used)
6. Supply Air (a shut off should be installed to allow FRL/reel service)

ACCESSORIES SUPPLIED:

- For #4 Motor:
 - Muffler with speed control (Figure 2).
 - Control valve with integral back pressure relief and flexible air line for connecting control valve to motor (Figure 4).
- For #6 Motor:
 - Muffler (Figure 3).
 - Control valve with integral back pressure relief and flexible air line for connecting control valve to motor (Figure 4).

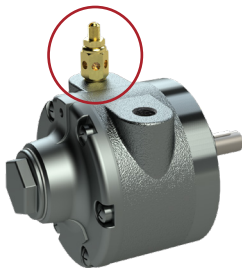

FIGURE 2: #4 Gast Air Motor with speed regulator muffler



FIGURE 3: #6 Gast Air Motor with muffler

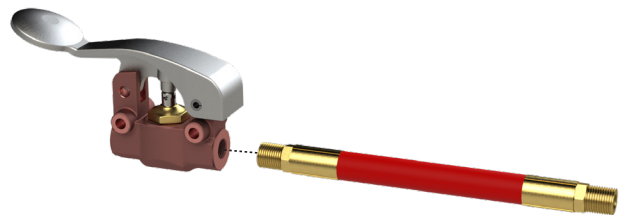

FIGURE 4: Supplied Control Valve and Flexible Air Line

REQUIRED BUT NOT SUPPLIED:

- FRL Combination or separate filter, regulator, & lubricator if a combination unit is not available.
- Reserve air tank if the air compressor can not sustain required air pressure & flow rate (see back for motor requirements).
- Air line shut off.

TSB 2013.08.003

Installing a Compressed Air Rewind Powered Reel

INSTALLATION

1. Securely mount reel using adequate hardware and mounting holes in feet.
2. Locate FRL in accessible point as close to the reel as possible. If using separate components mount oiler nearest the reel.
3. Connect air source and FRL to reel using appropriate size* air lines for your application. Refer to Figure 5 for air inlet versus rotation direction.

**Air Lines should be motor port size or next NPT size larger.*

4. To avoid the need for shutting off the air system when servicing FRL control valve or reel motor install a line shut off valve before FRL.
5. Check all fittings & connections for leaks.

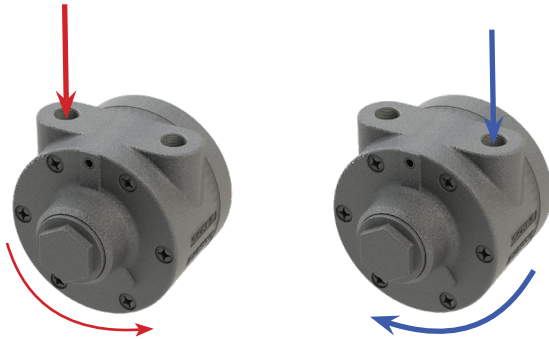

FIGURE 5: Note inlet versus rotation direction.

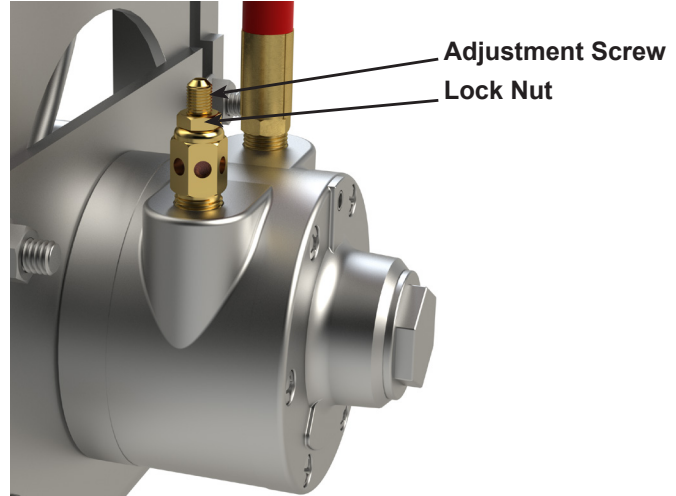

FIGURE 6: To change motor RPM loosen lock nut, turn adjustment screw in to slowdown motor, or out to speed up motor.

MAINTENANCE

1. Line oiler should be checked daily to maintain proper oil level.
2. Filter should be drained daily and cleaned frequently, depending upon type of service.
3. Check pressure regulator set between 90 psi and 100 psi.
4. Check chain tension and tighten as needed. Chain tension should be about ¼" between sprockets. Lubricate chain to prevent excessive stretching.

MOTOR LUBRICATION

- 10wt detergent oil is to be used such as Gast AD220 oil. However if it is not available a 10w30 oil may be used.
- Oiler should be set to 1 drop/50cfm.
- Lubricator should be within 20 feet, or closer, to the reel.

AIR MOTOR SPECS		
	#4 GAST	#6 GAST
INLET PORTS	1/4" NPT	1/2" NPT
REQUIRED AIRFLOW	20-30 CFM	30-50 CFM
MAX. INLET PRESSURE	100 PSI	100 PSI
MOTOR SHAFT SIZE	Φ 1/2"	Φ 5/8"

MOTOR REPAIR:

- Refer to TSB 2013.08.009 for instructions to unstick a seized motor.
- Motor repair kits are available for Gast air motors.
The kits include Vanes, Gaskets, Bearings, Springs, Pins, O-Rings & Shaft Seals
 - #4 Repair Kit - Hannay P/N 9919.0002
 - #6 Repair Kit – Hannay P/N 9919.0003