

C
10.5"
267



Hannay Reels®
The reel leader.

Welding Reels

| Mobile and Fixed Installations | Arc Welding | Gas Welding | Cutting Operations |



Family owned and operated since 1933

CONTENTS

Hannay hose reels come in all sizes and capacities.

Reel Type	Page
Arc Welding Reels	
Model WCR11-17-19	3
Series SWCR/WCR	4-5
Series TWCR	6
Gas Welding Reels	
Series N400	7
Series 2400	8
Series G2400	9
Welding Hose & Cable Specifications	10
Hannay Reels Sales Policies	11

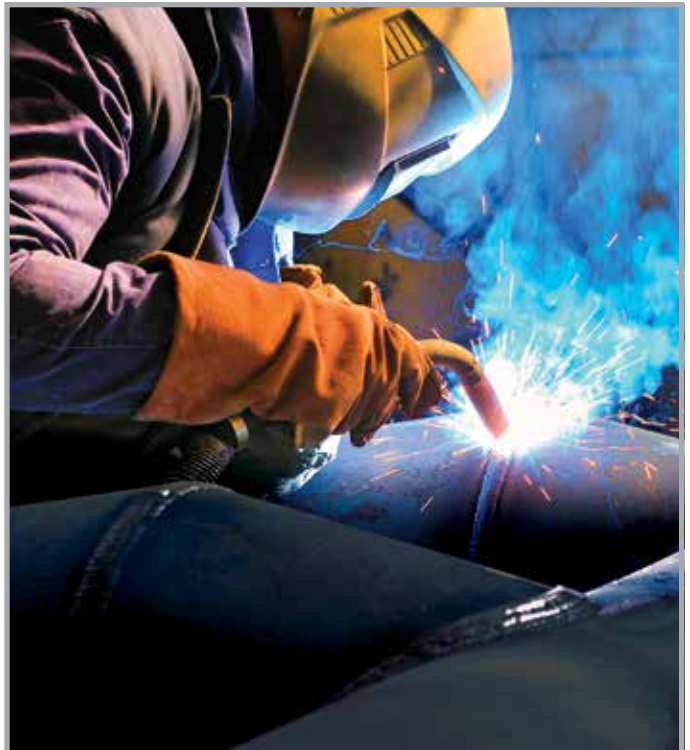

Only one reel bonds quality and value.

When it comes to safety and efficiency, you can count on Hannay Reels. Used worldwide, our durable, dependable reels help your operation run smoothly – and reduce workplace accidents – by keeping hoses and cables organized and off the floor.

We offer the widest variety of arc and gas welding reels in the industry. Our high quality reels are built to last and engineered specifically for welding – never retrofitted to the job – so you can expect unsurpassed fit and function.

Uses:

- Mobile and fixed installations
- Arc welding
- Gas welding
- Cutting operations

Model WCR11-17-19

• Manual Rewind • Portable Reel

To handle #2 through 4/0 cable to 400 amps.

- For use with single-conductor electrode cable or for grounding lead.
- 400-amp rotary electrical device.
- Rugged portable reel with carrying handle.
- Instant use with any cable length unwound.
- Quick connection to your welder.
- Manual rewind (permanently attached knob).
- Adjustable friction brake.



Standard configuration shown



Protective Ground Lug Boot

Part No. 9955.0202
Standard on reel

PARTS DRAWING – ISO 110

Model Number	Cable Capacity of Reel feet m							Approx. Weight lb. kg		Reel Dimensions*** in. mm									
	Gauge of Cable									A	B	C	D	E	F	G	H	X	Y
	O.D. in. O.D. mm	#2 .50 10	#1 .58 15	1/0 .62 16	2/0 .67 17	3/0 .72 18	4/0 .81 21	NET	SHIP										
WCR11-17-19	200 61	150 46	100 30	75 23	75 23	50 15	24 11	46* 21	9.25 235	6 152	10.5 267	15.5 394	16.5 419	13 330	18.81 478	8.69 221	7 178	11.5 292	

Notes:

1. Specifications subject to change.
 2. **Be sure to check dimensions and weights prior to ordering.**
 3. For welding hose and cable specifications see page 10.
 4. **Finish:** Refer to Ordering & Accessory catalog page 19.
- * Dimensional weight applies when shipped as a parcel package (via FedEx or UPS Ground).
***X, Y indicate mounting holes. See page 10.

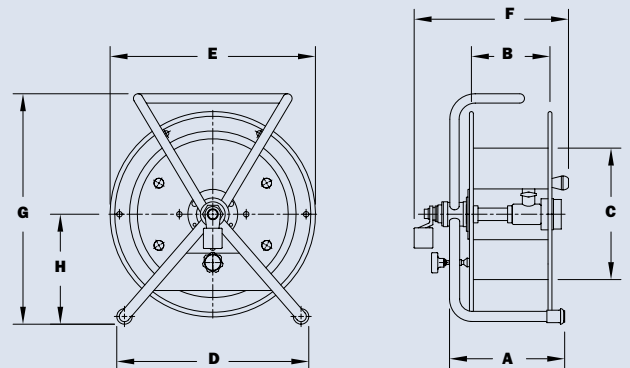

Series **SWCR/WCR**

• Spring, Power or Manual Rewind • Arc Welding

To handle #2 through 4/0 cable to 400 amps.

- For use with single-conductor electrode cable or grounding lead.
- 400-amp rated rotary electrical device.
- Instant use with any cable length unwound.
- Quick connection to your welder.
- Easy access and greaseable zerck fitting.

SWCR

- Non-sparking ratchet assembly.
- Declutching arbor is provided to prevent damage from reverse winding.
- A cable stop should be used.
- Four-way roller assembly. Roller position must be specified.

WCR

- Gear-driven crank rewind, chain and sprocket powered by an electric, hydraulic or compressed air motor or spring rewind.
- Auxiliary rewind and pinion brake standard.
- Chain guards are available, must be specified.
- Rollers and roller mounting brackets are accessory items. Specify roller position.



Series SWCR

Standard SR configuration shown with optional cable and stop



Series WCR

Standard configuration shown with Air Rewind (AWCR) option



Protective Ground Lug Boot

Part No. 9955.0202
Standard on reel

Series SWCR/WCR

• Spring, Power or Manual Rewind • Arc Welding

PARTS DRAWING – SWCR ISO 94; WCR ISO 188

Model Number For power rewind see Note 4	Cable Capacity of Reel feet m						Approx. Weight Crank/Spring Rewind lb. kg see Note 3		Std. Roller Assy.	Reel Dimensions*** in. mm											
	Gauge of Cable						NET	SHIP		A	B	C	D	E	F		G	H	X	Y	
	#2	#1	1/0	2/0	3/0	4/0									CRANK	PWR.					SPRING
SWCR716-23-24-15.5B	–	–	–	–	–	40	81	116	R204	9.25	3	15.5	24.5	22.75	–	–	10.88	23.88	12.5	4.5	20
	–	–	–	–	–	12	37	53		235	76	394	622	578	–	–	276	607	318	114	508
SWCR716-23-24-15.5G	85	85	60	60	60	–	85	120	R204	9.25	3	15.5	24.5	22.75	–	–	10.88	23.88	12.5	4.5	20
	26	26	18	18	18	–	39	54		235	76	394	622	578	–	–	276	607	318	114	508
SWCR716-25-26-15.5B	–	–	–	–	60	50	94	126	R204	9.25	3	15.5	26.25	24.75	–	–	10.88	25.88	13.5	4.5	21.75
	–	–	–	–	18	15	41	57		235	76	394	667	629	–	–	276	657	343	114	552
SWCR716-25-26-15.5A	–	–	100	–	–	–	106	141	R205	10.25	3	15.5	26.25	24.75	–	–	12.12	25.88	13.5	5.5	21.75
	–	–	30	–	–	–	48	64		260	76	394	667	629	–	–	308	657	343	140	552
WCR16-19-21	–	275	200	200	150	150	71	106	–	13	7.5	10.5	20.5	18.75	15	19.75	–	21.62	12.25	7.75	16.75
	–	84	61	61	46	46	32	48		330	191	267	521	476	381	502	–	549	311	197	425
WCR16-23-24	–	–	–	–	300	200	78	113	–	13	7.5	10.5	20.5	22.75	15	19.75	–	23.62	12.25	7.75	16.75
	–	–	–	–	91	61	35	51		330	191	267	521	578	381	502	–	600	311	197	425

Notes:

- Specifications subject to change.
- Upon request, reels can be supplied with drum lengths other than shown and with disc sizes in other diameters.
- Weights shown in chart are for crank or spring rewind models. ADD these amounts for power rewind models (Series WCR):

	Net lbs/kg	Ship lbs/kg
Electric	40/18.1	40/18.1
Hydraulic	20/9.1	20/9.1
Air	20/9.1	20/9.1

- When ordering power rewind Series WCR, prefix model number with:
A = Air Rewind
EP = Electric Rewind
HD = Hydraulic Rewind

(Air rewind reels are supplied with control valve and 18" air hose; 12v and 24v DC rewind reels are supplied with switch and solenoid; 115v AC rewind reels require double pole single throw switch which is not supplied, but can be ordered separately, hydraulic rewind reels are not supplied with control valve.)

- Be sure to check dimensions and weights prior to ordering.**
 - For welding hose and cable specifications see page 10.
 - Finish:** Refer to Ordering & Accessory catalog page 19.
- *** X, Y indicate mounting holes. See page 10.

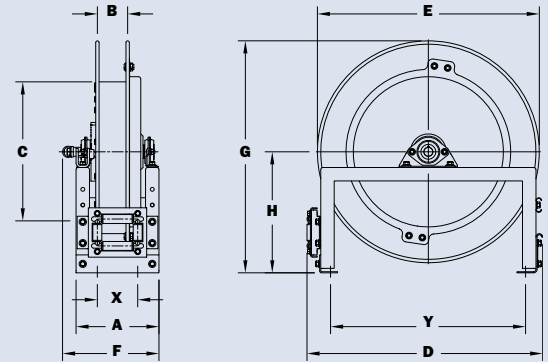

Series SWCR

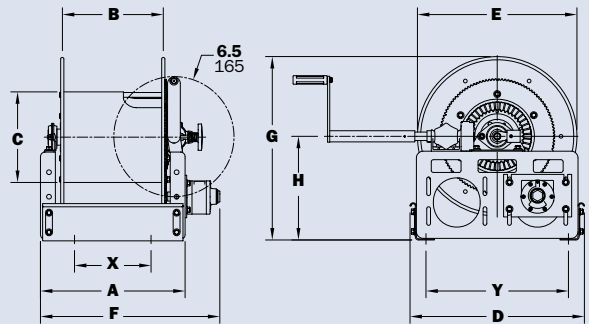

Series WCR

Available Roller Positions

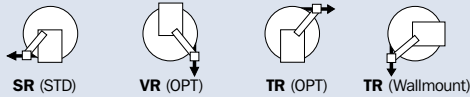

Series **TWCR**

• Manual Rewind • Twin Arc Welding

To handle #1 through 4/0 cable to 400 amps.

- Designed to handle both grounding and arc welding leads on the same reel unit.
- Two independent spools to hold separate lengths of welding cable.
- 400-amp rotary electrical device for instant and constant use.
- Instant use with any cable length unwound.
- Gear-driven crank rewind with a removable handle.
- Dual pinion brakes.
- Rollers and roller mounting brackets are accessory items. Specify roller position.



Standard configuration shown



Protective Ground Lug Boot

Part No. 9955.0202
Standard on reel

PARTS DRAWING – ISO 185

Model Number	Cable Capacity of Reel feet m					Approx. Weight Crank Rewind lb. kg		Reel Dimensions*** in. mm									
	O.D. in. O.D. mm	Gauge of Cable				NET	SHIP	A	B	C	D	E	F	G	H	X	Y
		#1	1/0	2/0	3/0												
TWCR 12-17-18	-	50	50	45	40	78	113	16.5	4	10.5	18	20.75	21	18.12	9.88	9	14.25
	-	15	15	14	12	35	51	419	102	267	457	527	533	460	251	229	362
TWCR 14-17-18	125	100	100	80	50	80	115	20.5	6	10.5	18	20.75	25	18.12	9.88	13	14.25
	38	30	30	24	15	36	52	521	152	267	457	527	635	460	251	330	362
TWCR 12-19-20	150	100	100	60	60	82	117	16.5	4	10.5	18.5	21	21	19.75	10.38	9	14.75
	46	30	30	18	18	37	53	419	102	267	470	533	533	502	264	229	375
TWCR 14-19-20	-	150	150	100	80	84	119	20.5	6	10.5	18.5	21	25	19.75	10.38	13	14.75
	-	46	46	30	24	38	54	521	152	267	470	533	635	502	264	330	375

Notes:

1. Specifications subject to change.
 2. **Be sure to check dimensions and weights prior to ordering.**
 3. For welding hose and cable specifications see page 10.
 4. Ship via freight only. UPS or FedEx shipping is not available on this series reel.
 5. **Finish:** Refer to Ordering & Accessory catalog page 19.
- *** X, Y indicate mounting holes. See page 10.

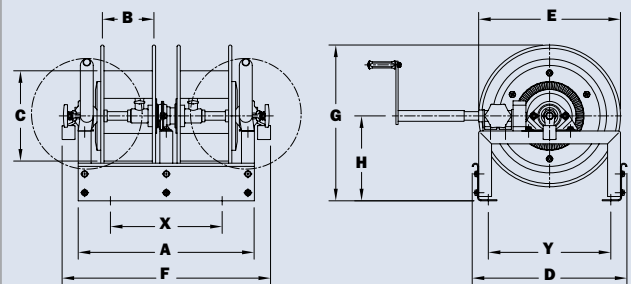

Series N400

• Oxy/Fuel Welding • Spring Rewind

To handle twin 1/4" or 3/8" I.D. welding hose.

- Heavy-duty spring motor.
- Non-sparking ratchet assembly.
- Declutching arbor to prevent damage from reverse winding.
- Standard inlets: 90° ball bearing swivel joints, 1/2" female NPT threads. Oxy/acet brass inlet adapters are available.
- Standard outlets: male 9/16"-18 threads, right-hand for oxygen, left-hand for gas.
- Pressures to 300 psi (21 bar).
- Standard fluid temperatures from -40° F to +250 °F (-40° C to +121° C). Optional temperature ratings available - consult factory.
- Type of gas used must be specified.
- 4-way roller assembly. SR position is standard, other configurations available, must specify.
- Hose stop is required.



Optional TR configuration shown with optional hose and stop

PARTS DRAWING – ISO 186

Model Number	Hose Capacity of Reel feet m			Approx. Weight lb. kg		Standard Roller Assy.	Reel Dimensions*** in. mm							
	I.D. in. mm	1/4 6	3/8 9	NET	SHIP		A	B	C	E	F	G	H	X
	O.D. in. mm	.53 13	.66 17											
N416-17-18-8L		2/50	–	64	69*	N204	10	4	8	19.5	15	17.38	9.13	8
		2/15	–	29	31		254	102	203	495	381	441	232	203
N416-19-20-8L		–	2/50	68	74*	N204	10	4	8	20.75	15	20	10.62	8
		–	2/15	31	34		254	102	203	527	381	508	270	203
N416-19-20-10.5C		2/25	2/25	70	77*	N204	10	4	10.5	20.75	15	20	10.62	8
		2/8	2/8	32	35		254	102	267	527	381	508	270	203
N416-19-20-8J		2/50	2/50	74	80*	N204	10	4	8	20.75	15	20	10.62	8
		2/15	2/15	34	36		254	102	203	527	381	508	270	203
N417-23-24-10.5G		2/75	2/75	94	115	N205	11	5	10.5	24	16	24	12.62	9
		2/23	2/23	43	52		279	127	267	610	406	610	320	229
N417-25-26-10.5G		2/100	2/100	97	132	N205	11	5	10.5	25.5	16	26	13.62	9
		2/30	2/30	43	52		279	127	267	648	406	660	346	229

Notes:

A hose stop is necessary to keep spring from unwinding.

1. Specifications subject to change.
2. Reel models and capacities shown are for standard drag applications; for vertical lift applications, consult factory.
3. Other sizes, from standard components, available on request.
4. **Finish:** Refer to Ordering & Accessory catalog page 19.

5. Be sure to check dimensions and weights prior to ordering.

NOTICE: A flexible connector must be used between the inlet pipe and the inlet swivel joint.
 * Dimensional weight may apply when shipped as a parcel package (via FedEx or UPS Ground).
 *** X, Y indicate mounting holes. See page 10.

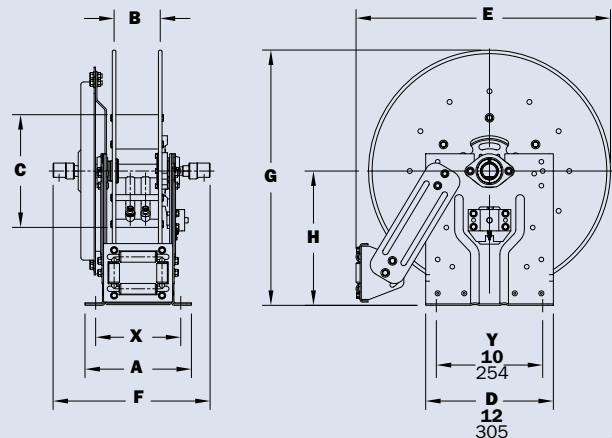

Available Roller Positions

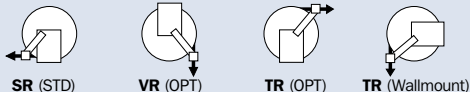

Series 2400

• Manual (MX) or Power Rewind • Oxy/Fuel Welding

To handle twin 1/4" through 3/8" welding hose.

- MX chain-driven crank rewind or powered by a compressed air or hydraulic motor.
- MX rewind reels supplied with a pinion brake.
- Power reels not supplied with a brake.
- Standard inlets: 90° ball bearing swivel joints with 1/2" female NPT threads. Oxy/acet brass inlet adapters are available.
- Standard outlets are male 9/16"-18 threads. Right-hand for oxygen, left-hand for gas.
- Pressures to 300 psi (21 bar).
- Standard fluid temperatures from -40° F to +250 °F (-40° C to +121° C). Optional temperature ratings available - consult factory.
- Type of gas used must be specified.



Series MX2400

Standard configuration shown with Manual Rewind (MX)

Series A2400

Standard configuration shown with Air Rewind (A) option

Model A2400

- Rollers and roller mounting brackets are accessory items. Specify roller position.

PARTS DRAWING – ISO 187 POWER; ISO 213 MANUAL (MX)

Model Number For power rewind see Note 5	Hose Capacity of Reel feet m			Approx. Weight lb. kg		Reel Dimensions*** in. mm						
	I.D. in. mm	1/4 6	3/8 9	NET	SHIP	A	B	E MX	E POWER	F MX	F POWER	X
	O.D. in. mm	.53 13	.66 17									
MX2414-17-18		2/100	2/75	31	68*	11	6	19.12	19	24.5	18.5	9.5
		2/30	2/23	14	31	279	152	486	483	622	470	241
MX2416-17-18		2/150	2/100	32	80*	13	8	19.12	19	26.5	20.5	11.5
		2/46	2/30	15	31	330	203	486	483	673	521	292
MX2420-17-18		-	2/150	34	98*	17	12	19.12	19	30.5	24.5	15.5
		-	2/46	15	44	432	305	486	483	775	622	394
MX2426-17-18		-	2/200	36	110*	23	18	19.12	19	36.5	30.5	21.5
		-	2/61	16	50	584	457	486	483	927	775	546

Notes:

- Specifications subject to change.
- Upon request, reels can be supplied with drum lengths other than shown and with disc sizes in other diameters.
- Weights shown in chart are for crank rewind models. ADD these amounts for power rewind models:

	Net lbs/kg	Ship lbs/kg
Hydraulic	15/6.8	15/6.8
Air	15/6.8	15/6.8
- Dimension "F" is the overall length of standard model reels. On crank rewind models, the dimension shown is with the crank in rewind position. Reels require 2" clearance to remove crank handle.
- When ordering power rewind models replace MX prefix with:
 - A** = Air Rewind
 - HD** = Hydraulic Rewind (Air rewind reels are supplied with control valve and 18" air hose; hydraulic rewind reels are not supplied with control valve.)

- Be sure to check dimensions and weights prior to ordering.**
 - For welding hose and cable specifications see page 10.
 - Some roller options may prohibit the use of our molded chain guard.
 - See page 9 for optional External Mounting Brackets.
 - Finish:** Refer to Ordering & Accessory catalog page 19.
- NOTICE:** A Flexible Connector must be used between the inlet pipe and the inlet swivel joint.
- * Dimensional weight may apply when shipped as a parcel package (via FedEx or UPS Ground).
- *** X, Y indicate mounting holes. See page 10.

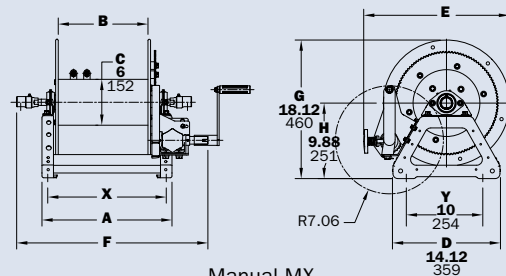

Manual MX

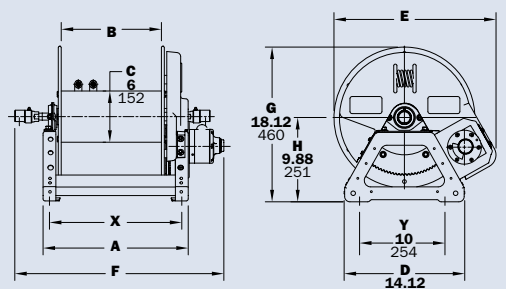

Power Rewind

Series **G2400**

• Manual Rewind • Oxy/Fuel Welding

To handle twin 1/4" through 3/8" I.D. hose.

- Gear-driven crank rewind with pinion brake.
- Standard inlets: 90° ball bearing swivel joints 1/2" female NPT threads. Oxy/acet brass inlet adapters are available.
- Standard outlets are male 9/16"-18 threads. Right-hand for oxygen, left-hand for gas.
- Pressures to 300 psi (21 bar).
- Standard fluid temperatures from -40° F to +250 °F (-40° C to +121° C). Optional temperature ratings available - consult factory.
- Type of gas used must be specified.



Standard gear-driven crank rewind shown



Optional external mounting brackets

Part No. 9906.0025.
Add 2-1/2" to the X dimensions shown in the chart.

PARTS DRAWING – ISO 205

Model Number	Hose Capacity of Reel feet m			Approx. Weight Crank Rewind lb. kg		Reel Dimensions*** in. mm			
	I.D. in. mm	1/4 6	3/8 10	NET	SHIP	A	B	F	X
	O.D. in. mm	.53 14	.66 17						
G2416-17-18-8	2/150	2/100		40	80*	13	8	18.88	11.5
	2/46	2/30		15	36	330	203	480	292
G2420-17-18-8	–	2/150		42	98*	17	12	22.88	15.5
	–	2/46		18	36	432	305	581	394
G2426-17-18-8	–	2/200		44	110*	23	18	28.88	21.5
	–	2/61		19	50	584	457	734	546

Notes:

1. Specifications subject to change.
2. Upon request, reels can be supplied with drum lengths other than shown.
3. **Be sure to check dimensions and weights prior to ordering.**
4. For welding hose and cable specifications see page 10.
5. Some roller options may prohibit the use of our molded chain guard.
6. **Finish:** Refer to Ordering & Accessory catalog page 19.

NOTICE: A Flexible Connector must be used between the inlet pipe and the inlet swivel joint.

* Dimensional weight may apply when shipped as a parcel package (via FedEx or UPS Ground).

*** X, Y indicate mounting holes. See page 10.

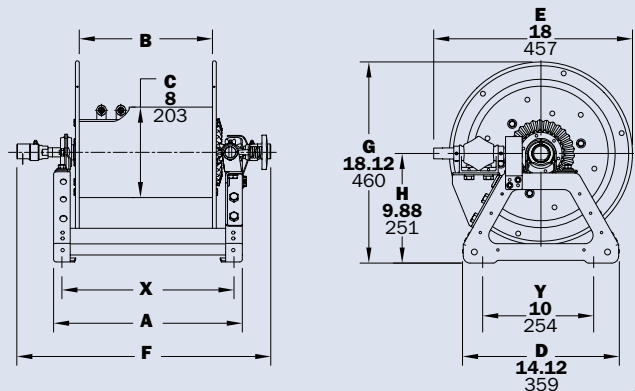

Welding Hose & Cable **Specifications**

Welding Hose

Our oxygen/acetylene grade R hose assemblies with inside diameters of 1/4" and 3/8" have working pressures of 200 psi (14 bar), working temperatures of -40°F to +200°F (-40°C to +93°C), and have an EPDM core and cover with one textile braid reinforcement. This hose is designed for oxygen/acetylene only. Grade T oxygen/acetylene, propane, or M.A.P.P. hose is also available.

For hose assembly details and pricing, consult your Hannay dealer or factory.

WELDING AND GROUNDING CABLE

Wire Size (AWG)	Area (Per Conductor)	
	Circ. Mills	Sq. mm
#2	66,500	33.7
#1	84,000	42.6
#1/0	105,600	53.5
#2/0	133,100	67.4
#3/0	167,800	85.0
#4/0	211,600	107.2



Mounting Hole Sizes

N Series Reels	7/16" wide x 7/8" long slot running front to back
Pressed Frame Reels and Channel Framed Reels	7/16" wide x 7/8" long slot running left to right
Series 2000	13/32" round holes

Hannay Reels Sales Policies

Hannay Reels 3-Year Limited Warranty

Products manufactured by Hannay Reels, Inc. ("Hannay") are warranted for 3 years from date of shipment when properly installed, maintained, and operated in accordance with Hannay instructions. In no event will Hannay have a warranty obligation for normal wear and tear, or for products that have, at Hannay's determination, been subjected to accident, abuse, misapplication, improper installation or improper maintenance. Common examples of normal wear and tear would include paint finish, swivel joint seal wear, and switch or motor brush wear.

Hannay makes no warranties, express or implied, other than those included in this warranty statement, and we disclaim any implied warrant of merchantability or fitness for any particular purpose. Hannay will not be liable for any consequential, incidental, or indirect damages from any cause whatsoever.

Failure to use a flexible inlet connection on any live hose reel will void the swivel joint warranty. Failure to use a properly sized circuit breaker with any electric rewind motor will void the electric motor warranty. Failure to use a filter and lubricator on any air rewind motor will void the air motor warranty. Failure to follow all procedures outlined in the Safety Guidelines document will void the warranty.

Components not manufactured by Hannay will be subject to the original manufacturers' warranties. Examples of such components include: hose and cable, motors, speed controls, and switches, swivel joints and seals, slip ring and brush assemblies.

Equipment which proves to be defective upon our inspection will be replaced free of charge, including freight to the customer. Our responsibility ceases upon delivery to any common carrier and we do not, unless previously instructed, insure shipments beyond point of delivery to such carrier. **No material will be accepted for return without a return goods authorization (RGA).** This warranty extends to the replacement or repair of the reel or part (no labor).

Hannay reserves the right to modify or alter materials, dimensions, design, and construction when necessary to improve the performance of the reel and/or accessories, or to meet delivery requirements.

Notice on Reel Finish

Standard finish on Hannay reels is a high performance enamel paint. Standard color is metallic graphite. Other colors available, please consult factory.

Most of the major components on standard reels are e-coated prior to receiving final topcoat paint finish. This combination of e-coat and enamel topcoat will meet the finish requirements of most customer applications and environments.

In cases where requirements cannot be met with the standard finish, Hannay Reels can coat any model reel with an automotive primer, allowing application of final coating at your facility.

Alternatively, Hannay Reels can provide a quote for matching a customer-provided paint specification. For further information, please contact your Hannay Reels sales engineer and a special paint request form will be sent to you.

For environments where no paint finish is suitable, we offer both aluminum and stainless steel (304 grade) construction on most reel models.

Return Goods Policy

All Hannay reels are built to order. These orders are typically placed into production within 1 business day of receipt. Once production begins, it may not be possible to cancel the order.

To prevent returns because the wrong reels or parts were ordered, please use the Hannay Reels Spec Worksheet (either online or from our Ordering & Accessory Guide) when specifying reels. Be sure to include any size, weight, pressure and/or material compatibility limitations for the application.

In the event that an item does need to be returned for credit, repair or replacement, prior approval must be obtained from Hannay Reels. Upon your request, we will send a Return Goods

Authorization (RGA) form. A signed copy of this form must accompany the material when returned to us, with the RGA number clearly showing on the outside of the box—a label is provided to you that you can print and attach. No product will be accepted for return or credit without an authorized RGA number.

All material must be returned prepaid, unless otherwise noted on our RGA. No return will be accepted that has been damaged due to improper return packaging, tampered with or altered from its original condition. Our restocking and handling fee is a minimum of 25% for standard catalog reels and parts. Custom reels specially built to customer specifications cannot be returned for any reason.

Find reels for every need.

Learn more about all of our reels, including specs, drawings and even how to select the right reels and accessories for your industry.



Ordering & Accessory Guide

- Selecting the right reel
- Reel components
- Available accessories
- How to spec and order reels and accessories
- Ordering options
- Hannay Reels policies

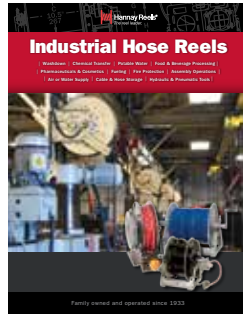

Industrial Hose Reels

- High pressure/low pressure reels
- Air/Lube/Grease reels
- Fueling
- Washdown/Power Wash
- Industrial Fire Protection
- Hydraulic/Pneumatic applications
- Hose Storage

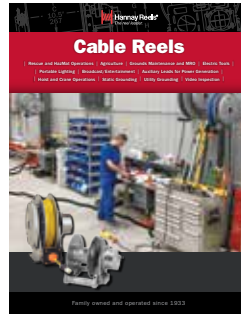

Cable Reels

- Electric Tools
- Crane operations
- Portable Lighting
- Live and storage reels
- Video/Broadcast
- Static and Utility grounding reels

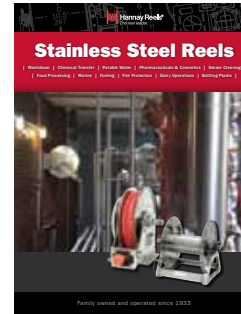

Stainless Steel Reels

- Washdown/Power Wash
- Food & Beverage Processing
- Chemical Processing
- Potable Water
- Fueling
- Steam Cleaning

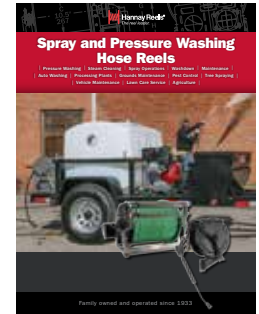

Spray and Pressure Washing Hose Reels

- Washdown/Power Wash
- Pest Control/Fertilizers
- Air/Water/Grease
- Steam Cleaning
- Spray operations
- Portable hose reels

View all our reel catalogs online at hannay.com



Family owned and operated since 1933, Hannay Reels is the world leader in both OEM and aftermarket applications. Hannay offers thousands of standard hose reel and cable reel models, as well as unmatched custom capabilities. We can easily and affordably customize a reel to meet your exact specifications – built to last, delivered fast. Additional catalogs are available through your local Hannay Reels dealer or online at hannay.com.



553 State Route 143 | Westerlo, New York 12193
Email: reels@hannay.com | hannay.com



All Hannay reels are constructed of quality heavy gauge steel (optional aluminum or stainless steel also available on most models).

