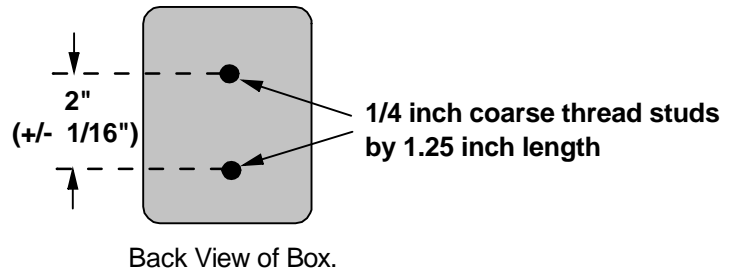

SB1240SR Installation Instructions

Application:

The **SB1240SR** Switch Box performs the Forward/Reverse and Momentary Power On/Off switching function to the reel motor. The SB1240SR contains a 40 Amp Circuit Breaker and is suitable for 12 Volt or 24 Volt Permanent Magnet DC motors, **up to 1/3 h.p.** For higher than 1/3 h.p. motors, the all electronic MD12HDSR forward/reverse speed control must be used. The MD12HDSR is rated for motors up to 3/4 h.p.

Mounting:

Remove the nuts from the mounting studs and use these nuts with 1/4" lockwashers to secure the Box to your mounting site.



Wiring Instructions:

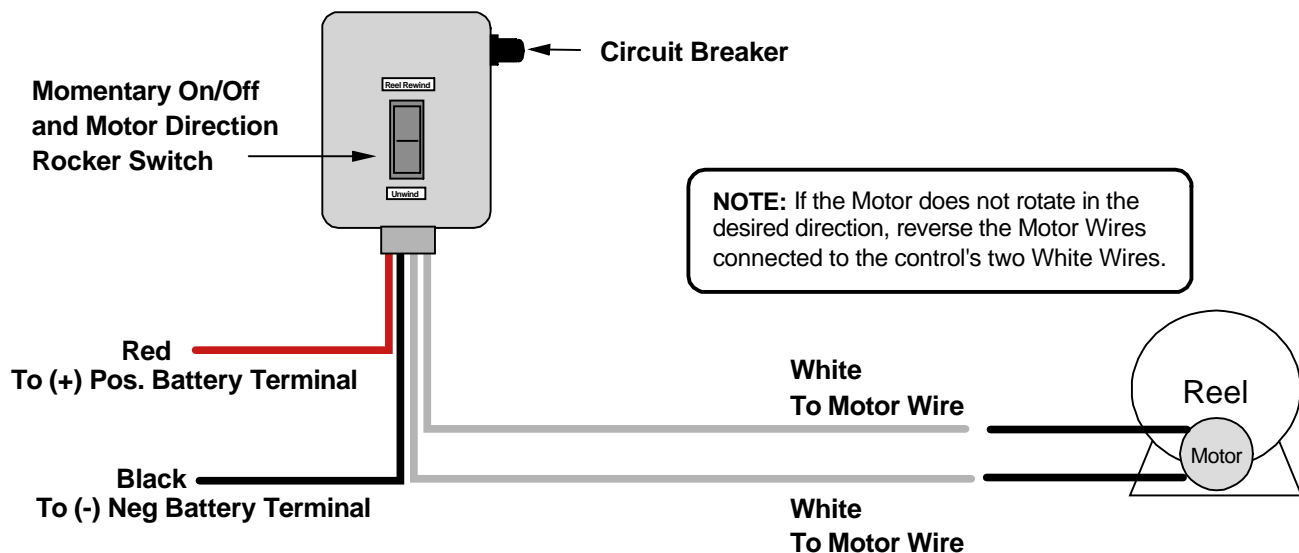

Warranty:

The SB1240SR is warranted by the manufacturer to be defect free from faulty materials or workmanship. If any defect is found within the 90 Day Warranty period, the company will repair the equipment without charge for materials and labor. After the 90 Day Warranty, the customer may send the unit in for a repair quote.